

1. MECHANICAL DIMENSION

Product Dimension

Unit:mm	General Tolerance :	X.X : ± 0.38
		X.XX : ± 0.20

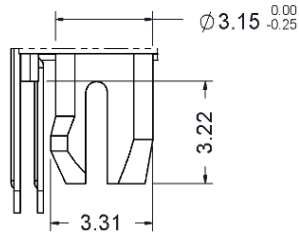

DETAIL A

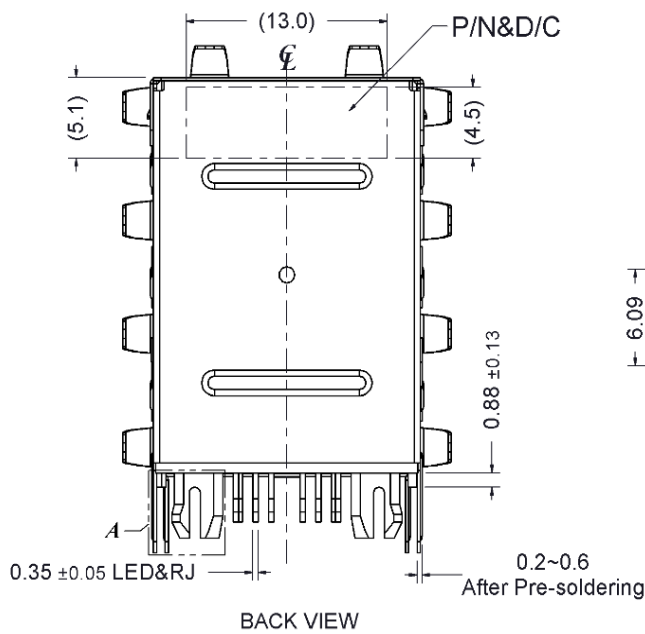
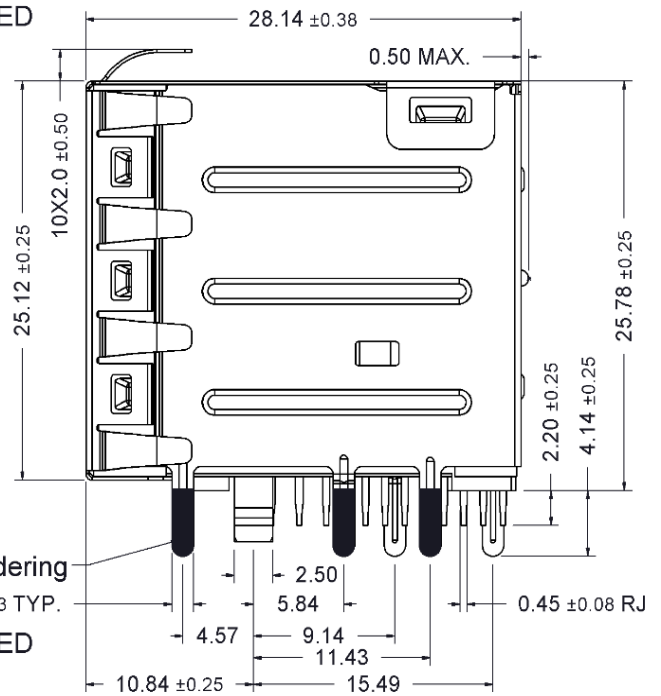
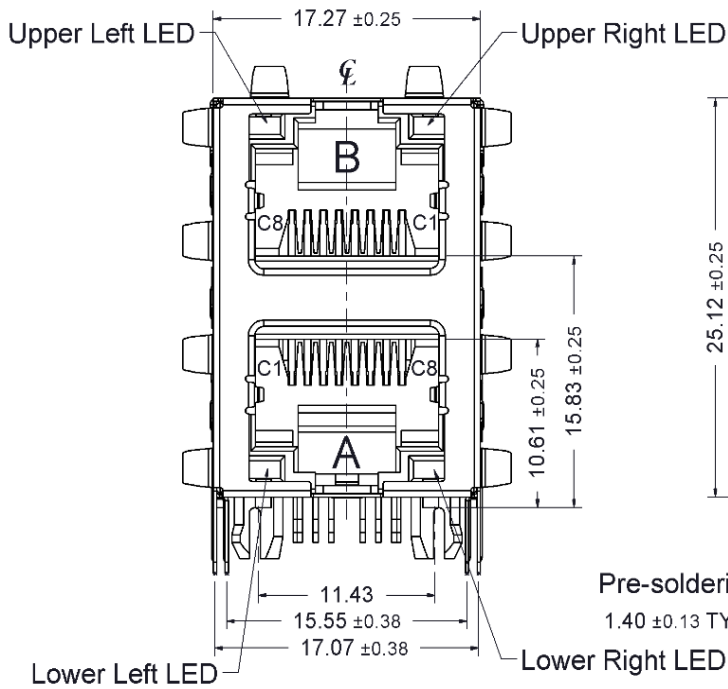
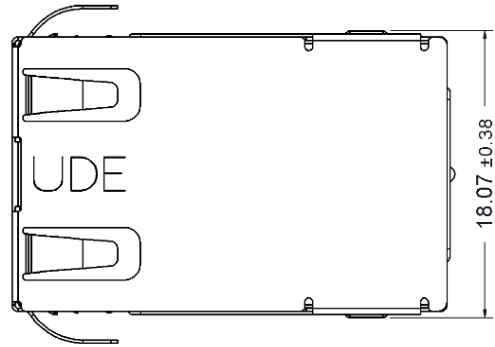

BACK VIEW

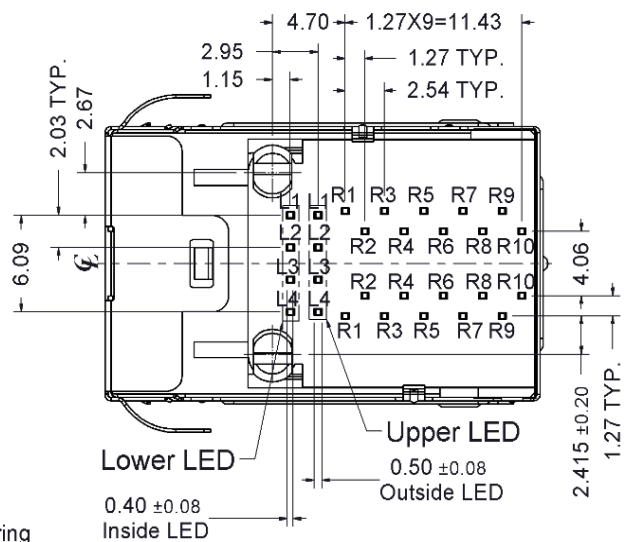

9. ELECTRICAL CHARACTERISTICS @25°C

PHY Side  
(Input)

Cable Side  
(RJ45 Output)

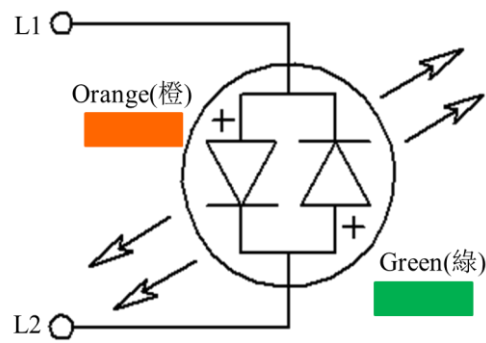
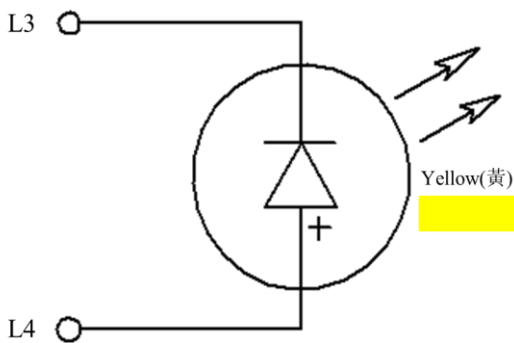
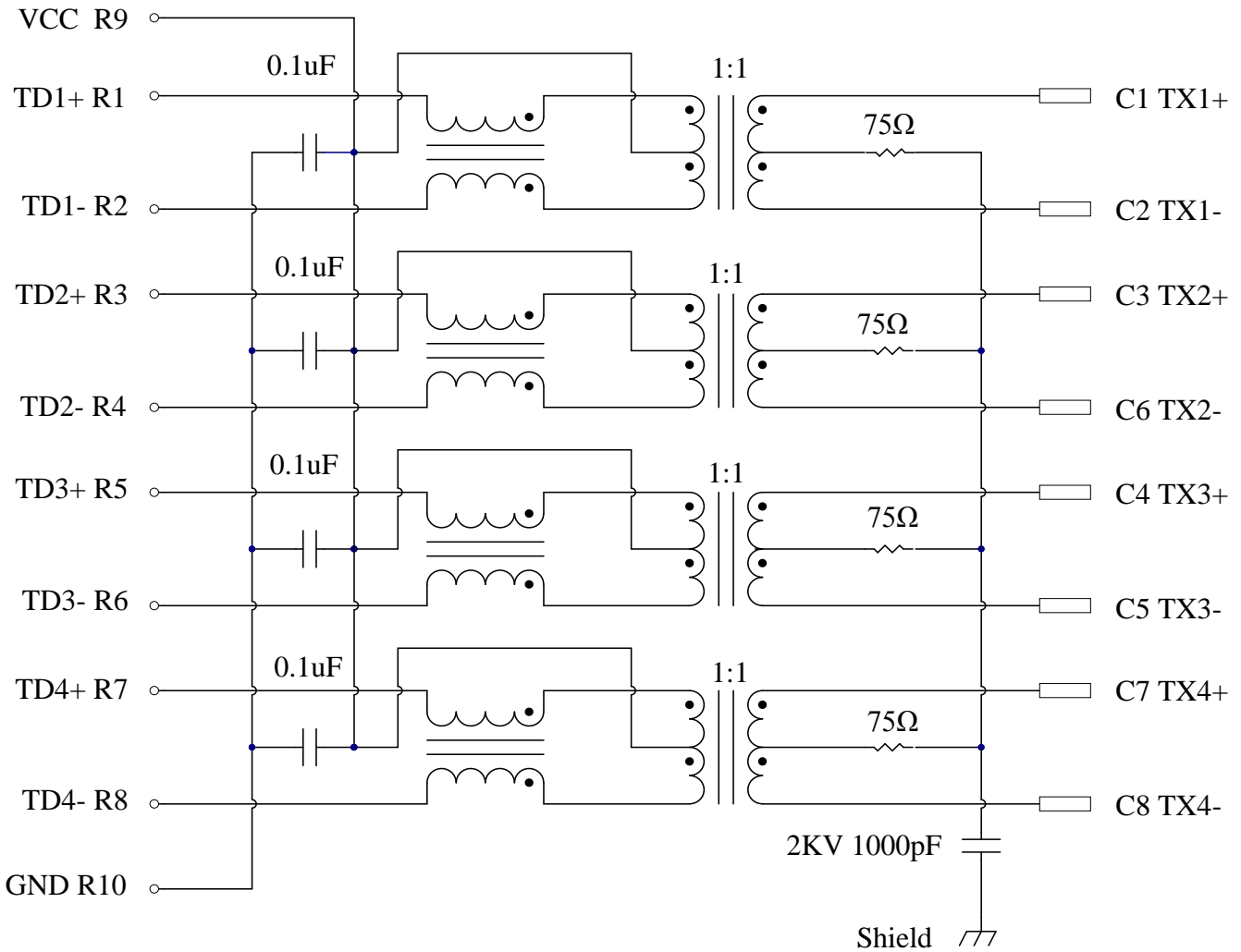

Emitting Color	$\lambda_p$ (nm)	$V_f$ @ $I_f=20mA$	$I_r$ @ $V_r=5V$
Yellow	588	1.7 ~2.6 V	10 $\mu$ A max.
Green	570	1.7 ~2.6 V	10 $\mu$ A max.
Orange	605	1.7 ~2.6 V	10 $\mu$ A max.